

1963

An optimized celestial-inertial navigation system

Thomas Luther Noack
Iowa State University

Follow this and additional works at: <https://lib.dr.iastate.edu/rtd>

 Part of the [Electrical and Electronics Commons](#)

Recommended Citation

Noack, Thomas Luther, "An optimized celestial-inertial navigation system " (1963). *Retrospective Theses and Dissertations*. 2943.
<https://lib.dr.iastate.edu/rtd/2943>

This Dissertation is brought to you for free and open access by the Iowa State University Capstones, Theses and Dissertations at Iowa State University Digital Repository. It has been accepted for inclusion in Retrospective Theses and Dissertations by an authorized administrator of Iowa State University Digital Repository. For more information, please contact digirep@iastate.edu.

This dissertation has been 64-3964
microfilmed exactly as received

NOACK, Thomas Luther, 1936-
AN OPTIMIZED CELESTIAL-INERTIAL NAVI-
GATION SYSTEM.

Iowa State University of Science and Technology
Ph.D., 1963
Engineering, electrical

University Microfilms, Inc., Ann Arbor, Michigan

AN OPTIMIZED CELESTIAL-INERTIAL NAVIGATION SYSTEM

by

Thomas Luther Noack

A Dissertation Submitted to the
Graduate Faculty in Partial Fulfillment of
The Requirements for the Degree of
DOCTOR OF PHILOSOPHY

Major Subject: Electrical Engineering

Approved:

Signature was redacted for privacy.

In Charge of Major Work

Signature was redacted for privacy.

Head of Major Department

Signature was redacted for privacy.

Dean of Graduate College

**Iowa State University
Of Science and Technology
Ames, Iowa**

1963

TABLE OF CONTENTS

	Page
INTRODUCTION	1
Statement of the Problem	1
Inertial Navigation	1
Celestial Navigation	12
Review of the Literature	16
THE ONE-CHANNEL INERTIAL-CELESTIAL SYSTEM	17
Description of the Problem	17
Optimization of the One-Channel System	17
The "Errorless" Filtering Case	21
THE OPTIMIZATION OF A TWO-CHANNEL SYSTEM	26
Description of the Problem	26
Analysis of the System with Negligible Platform Tilt	26
The System with Appreciable Platform Tilt	34
Closed-Loop System Configurations	38
CONCLUSIONS	42
LITERATURE CITED	44
ACKNOWLEDGEMENTS	45
APPENDIX A	46
The Non-Time-Stationary Optimum Filtering Problem	46

INTRODUCTION

Statement of the Problem

This thesis describes the optimization of a combined inertial-celestial navigation system. Throughout the thesis the following assumptions will be made: (1) that it is desired to minimize the mean square position error, (2) that the system is linear and perturbed by additive noise, (3) that the system is a locally level system, and (4) that the system operates at low velocities at a known distance from the center of the earth. Since the general solution to this problem is quite difficult several simpler versions of the problem will be analyzed. These may be solved by reasonably well-known techniques and the results are useful both from an intuitive standpoint and as practically useful methods of nearly optimizing a system. The three cases to be analyzed are: an inertial system with one channel, combined with a celestial body tracker; a two-channel system operating with a tracker with negligible platform tilt; and the more general case of a system with a tracker where platform inclination is not negligible. In all cases the results are applicable to a damped inertial system as well as a pure inertial system. The last-mentioned case is the most difficult to optimize. Before proceeding with the analysis it will be desirable to outline the basic principles involved in inertial and celestial navigation.

Inertial Navigation

Basic concepts

An inertial navigation system is one which measures its own

acceleration and thus calculates its own position in space. It has three essential components, a vector accelerometer, a stable platform, and a computer. The vector accelerometer is an instrument which measures acceleration in space. It does this by measuring the force on a test mass. If the mass is known, the total acceleration of the vehicle may be calculated using Newton's laws. The stable platform carries the vector accelerometer in a known attitude in space so that acceleration relative to known spatial coordinates. The computer calculates vehicle acceleration from the acceleration sensed by the accelerometer by adding the value of gravity, which is computed on the basis of the estimated position of the system. It supplies the torquing signals needed to keep the stable platform in the desired attitude in space. It integrates vehicle acceleration to obtain the system's velocity and position.

The accelerometer measures the force on a test mass. Thus, it senses vehicle acceleration plus gravity. If \underline{A} is the thrust acceleration $\frac{1}{m}\underline{F}$, \underline{g} the gravity vector, and \underline{R} the vehicle position vector, then $\ddot{\underline{R}} = \underline{g} + \underline{A}$. \underline{g} is a function of position and thus must be calculated using position information from the system. In inertial navigation systems in general, this is a crucial problem. However, in locally level systems, gravity is nearly constant relative to the platform axes and thus this computation is not a major source of error. The gravity feedback in the locally level system is basically a function of platform inclination.

The stable platform is kept in a known orientation by gyroscopes. A gyroscope is a rotating mass with a known angular momentum. If the

gyroscope is left undisturbed its angular momentum will remain constant and thus its axis of rotation will maintain a fixed attitude in space. A torque applied about an axis perpendicular to the axis of rotation of the gyro will cause precession, or rotation of the axis of rotation. Precession is described by the equation $\underline{T} = \underline{H} \times \underline{\omega}$, where \underline{T} is the external torque applied to the gyro, $\underline{\omega}$ is the precession angular velocity of the gyro, and \underline{H} is the angular momentum. In many cases, including the locally level system discussed here, it is desired to rotate the platform with respect to inertial space. This is done by applying known torques to the gyro. The torque to be applied is a function of the velocity and the position of the system.

The computer performs the integration of vehicle acceleration, the computation of the gravity vector, and the computation of the gyro torquing signals. For the purposes of this thesis it will be considered to be errorless.

It might be suspected from this discussion that errors in the instruments of an inertial system would tend to cause ever-increasing position errors. For this reason it is desirable, especially in cruise systems, to compare the position determined by the inertial system with some other position reference.

Locally level systems

A locally level system is one which is designed so that the platform is kept level at the computed position of the system. Consequently, the desired angular velocity of the platform is a function of the position of the system. This angular velocity is $\underline{\omega} = \underline{\omega}_s + \underline{\omega}_e$ where $\underline{\omega}$ is the angular

velocity required for the platform to remain locally level, and $\underline{\omega}_e$ is the angular velocity of the earth. The coordinate system used in this thesis is shown in Figure 1. In terms of this coordinate system the angular velocity $\underline{\omega}_s$ is

$$\frac{1}{x} \left[-\frac{\dot{y}}{R_0} \right] + \frac{1}{y} \left[\frac{\dot{x}}{R_0} \right] + \frac{1}{z} \left[-\frac{\dot{y} \tan \lambda}{R_0} \right] .$$

In a locally level system, the z-axis of the accelerometer is usually not mechanized, since this information is available otherwise in surface systems. A block diagram of a locally level system is shown in Figure 2.

Error analysis

As has been implied before, the errors in inertial navigation systems tend to propagate throughout the system and to increase with time. The instruments used in inertial navigation are imperfect, and the degree of accuracy demanded of the systems demands that the instruments be operated to the limits of their performance. Consequently, careful error analyses are very important in the design of an inertial navigation system. The errors in inertial navigation systems are of two basic types, instrument errors and alignment errors. Instrument errors arise from mechanical defects in the instruments and alignment errors are a result either of improper initial alignment of the system or of subsequent misalignment.

There are two major types of alignment error in the locally level system. One arises from platform tilt appearing in the output of the accelerometer and the other arises from velocity error being fed back via the torquing signals into the gyro. Since the gyro angular velocity is a function of the velocity of the system, if an error exists in the

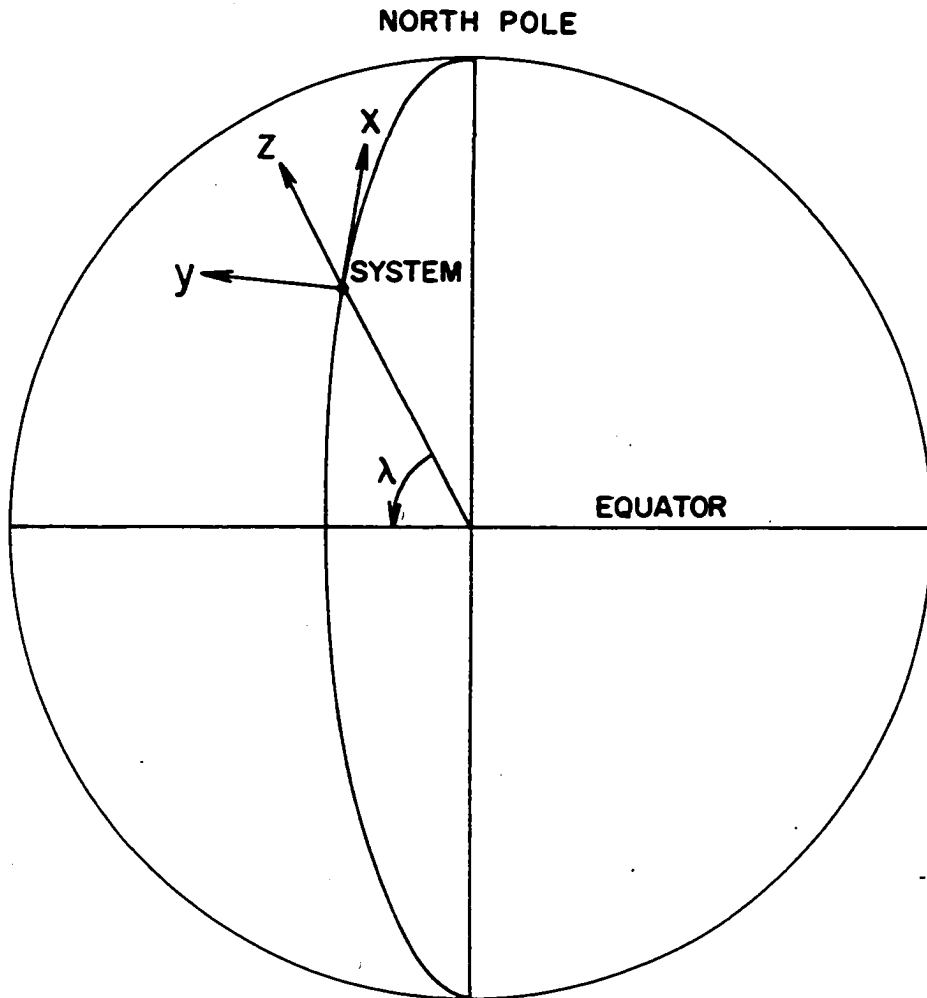

FIGURE 1. LOCALLY LEVEL COORDINATE SYSTEM

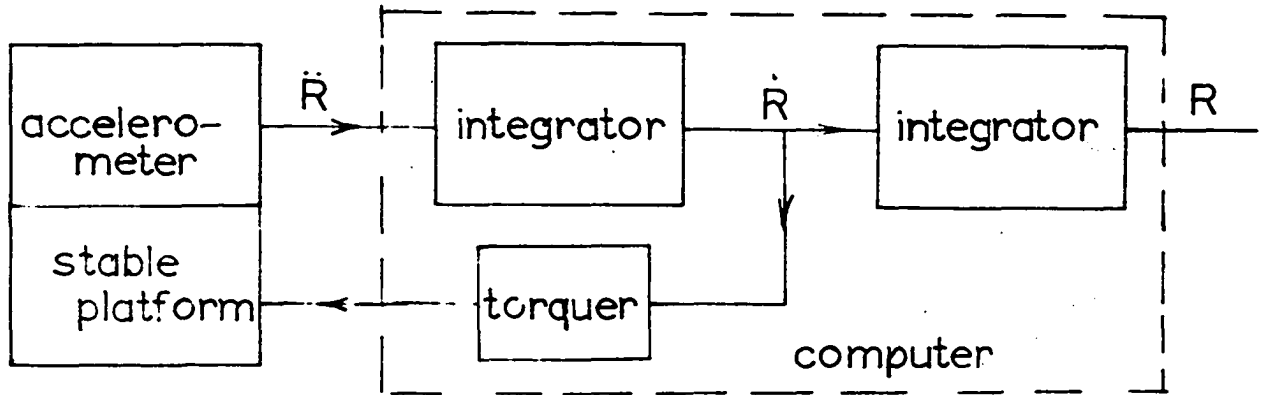

Figure 2. Locally level system block diagram.

velocity determined by the system, then the error will appear in the gyro torquing signal and thus in the platform tilt. This effect may be shown by considering the gyro angular velocity $\underline{\omega}$. The desired angular velocity is

$$\underline{\omega}_e + \frac{1}{R_x} \left[-\frac{\dot{y}}{R_0} \right] + \frac{1}{R_y} \left[\frac{\dot{x}}{R_0} \right]$$

and the actual angular velocity is

$$\underline{\omega}_e + \frac{1}{R_x} \left[-\frac{\dot{y} + \Delta\dot{y}}{R_0} \right] + \frac{1}{R_y} \left[\frac{\dot{x} + \Delta\dot{x}}{R_0} \right] + \underline{\epsilon} .$$

The difference is

$$\dot{\phi} = \frac{1}{R_x} \left[-\frac{\Delta\dot{y}}{R_0} \right] + \frac{1}{R_y} \left[-\frac{\Delta\dot{x}}{R_0} \right] + \underline{\epsilon}$$

where ϕ is the platform tilt angle vector, and $\underline{\epsilon}$ is the gyro bias. If the accelerometer is tilted through the angle ϕ from the vertical, its output is $\underline{A} - \underline{A} \times \phi + \underline{\delta a}$ where $\underline{\delta a}$ is the accelerometer error. The difference between the accelerometer output and the actual thrust acceleration \underline{A} is then given by

$$\underline{\delta a} + \frac{1}{R_x} [a_y \phi_z - g \phi_y] + \frac{1}{R_y} [g \phi_x - a_x \phi_z]$$

assuming the output along the z axis of the accelerometer is disregarded. If the higher order products are neglected as being small, then the accelerometer error output is

$$\underline{\Delta \ddot{x}} = \frac{1}{R_x} [\delta a_x - g \phi_y] + \frac{1}{R_y} [\delta a_y + g \phi_x] .$$

The error outputs of each accelerometer are then $\underline{\Delta \ddot{x}} = \delta a_x - g \phi_y$ for the

x-axis accelerometer, and $\Delta\ddot{y} = \delta a_y + g\dot{\phi}_x$ for the y-axis accelerometer. The error output equations for the gyros are $\dot{\phi}_x = -\frac{\Delta\dot{y}}{R_0} + \epsilon_x$ and $\dot{\phi}_y = \frac{\Delta\dot{x}}{R_0} + \epsilon_y$.

These error output relations for the instruments may now be combined to produce the error model for the locally level system shown in Figure 3.

Damped inertial systems

If the pure inertial system discussed previously is modified by adding an independent velocity measuring device whose output is fed back into the accelerometer, a damped inertial system results. The block diagram for the damped inertial system is shown in Figure 4. The output of the velocity meter is $\dot{R} + \delta v$ where δv is the instrument error of the velocity meter. The difference between the output of the velocity meter and the system velocity $\dot{R} + \Delta R$ is then $\delta v - \Delta R$. The error model for the damped inertial system can then be set as shown in Figure 5.

Error transfer functions and error propagation

Starting from the error models of Figures 3 and 5, the error transfer functions shown in Table 1 can be derived. If the velocity meter constant k is set to zero in the damped system, the undamped inertial system transfer functions are obtained directly. If a constant error is input at each of the error inputs δa_x , δv_x , and ϵ_y , the output errors shown in Table 2 are obtained. A new output error ψ_y is defined here as $\phi_y - \frac{\Delta x}{R_0}$. The only error input which causes an unbounded position error is ϵ_y . It may be seen that the error inputs from the accelerometer and the velocity meter can be lumped into one error input $\delta a_x + k\delta v_x$. The error model for the damped inertial system can be modified to take the form shown in

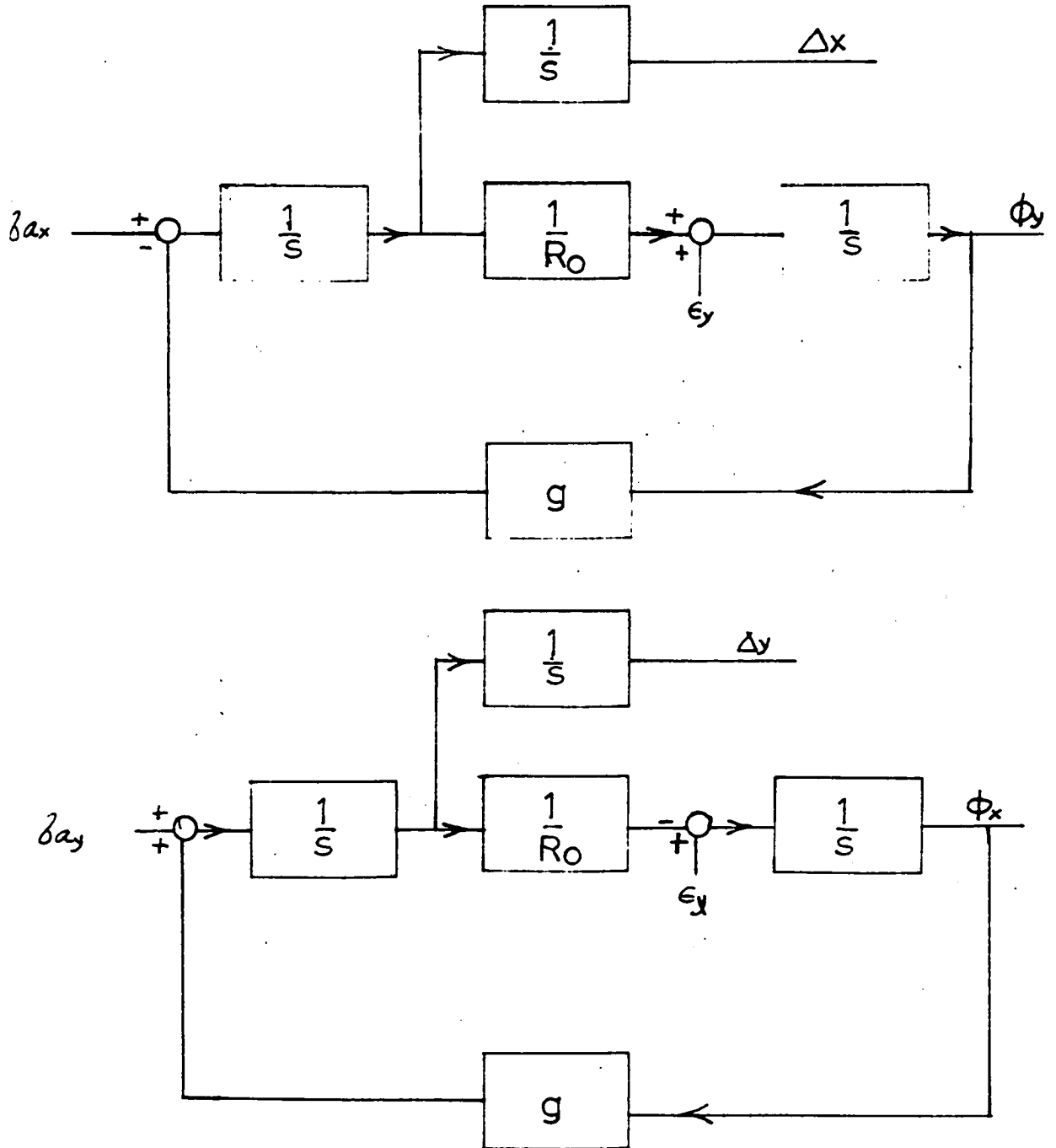

Figure 3. Pure inertial system error block diagram.

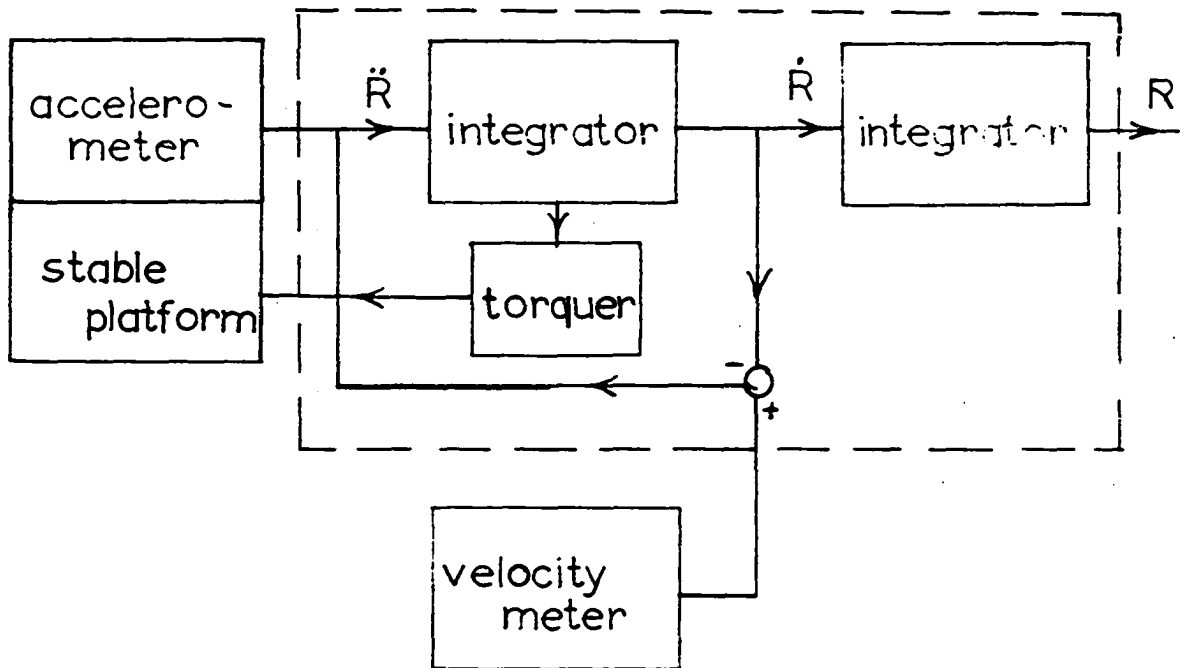

Figure 4. Damped inertial system block diagram.

Table 1. Error transfer functions for a damped inertial system

Error output	Error input		
	δa_x	δv_x	ϵ_y
Δ_x	$\frac{R_0}{R_0 s(s+k) + g}$	$\frac{kR_0}{R_0 s(s+k) + g}$	$\frac{-gR_0}{s[R_0 s(s+k) + g]}$
ϕ_y	$\frac{1}{R_0 s(s+k) + g}$	$\frac{k}{R_0 s(s+k) + g}$	$\frac{R_0(s+k)}{R_0 s(s+k) + g}$
ψ_y	0	0	$\frac{1}{s}$

Figure 6. This form will prove to be extremely useful in the analysis to follow. The substitutions $\omega_0 = \sqrt{\frac{g}{R_0}}$, $\zeta = \frac{k}{2\omega_0}$, and $\omega' = \omega_0 \sqrt{1 - \zeta^2}$ have been made in computing Table 2.

Relative seriousness of errors

It may be seen from Tables 1 and 2 that the only input error which causes an unbounded error is the gyro bias. For this reason, in cruise systems, the most critical components are the gyros. It is obviously very desirable to have some method of correcting this error. This is the purpose of combined inertial-celestial systems such as those discussed in this thesis. If a celestial body tracker is installed on a stable platform it measures the system error ψ . The use of this information to correct the effects of gyro bias would eliminate the errors which would increase in an unbounded fashion.

Table 2. Time domain form of error outputs for constant error inputs

Error output	Error input	Time domain form
Δ_x	$\delta a_x + k\delta v_x$	$\frac{\delta a_x + k\delta v_x}{\omega_o^2} [1 - e^{-\zeta\omega_o t} (\cos\omega' t + \frac{1}{\omega'} \sin\omega' t)]$
ϵ_y		$\frac{-g\epsilon_y}{\omega_o^2} \left[t \frac{e^{-\zeta\omega_o t}}{\omega'} \sin\omega' t - \frac{2}{\omega_o} [1 - e^{-\zeta\omega_o t} (\cos\omega' t + \frac{1}{\omega'} \sin\omega' t)] \right]$
ϕ_y	$\delta a_x + k\delta v_x$	$\frac{\delta a_x + k\delta v_x}{R\omega_o^2} [1 - e^{-\zeta\omega_o t} (\cos\omega' t + \frac{1}{\omega'} \sin\omega' t)]$
ϵ_y		$\epsilon_y \left[\frac{e^{-\zeta\omega_o t}}{\omega'} \sin\omega' t + \frac{2}{\omega_o} [1 - e^{-\zeta\omega_o t} (\cos\omega' t + \frac{1}{\omega'} \sin\omega' t)] \right]$
ψ_y	$\delta a_x + k\delta v_x$	0
ϵ_y		$\epsilon_y t$

Celestial Navigation

Celestial navigation is the process of navigation by making and interpreting observations on the positions of celestial bodies. In many cases, including both this system and the case of marine navigation with

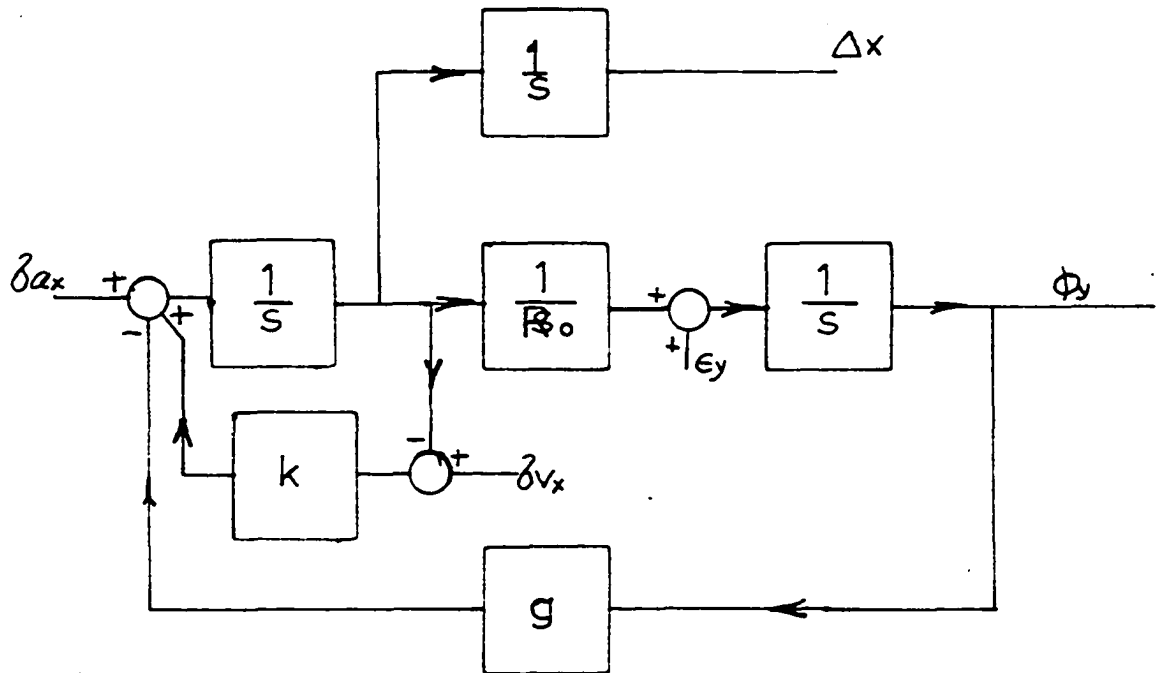

Figure 5. Error block diagram of one channel of a damped inertial system

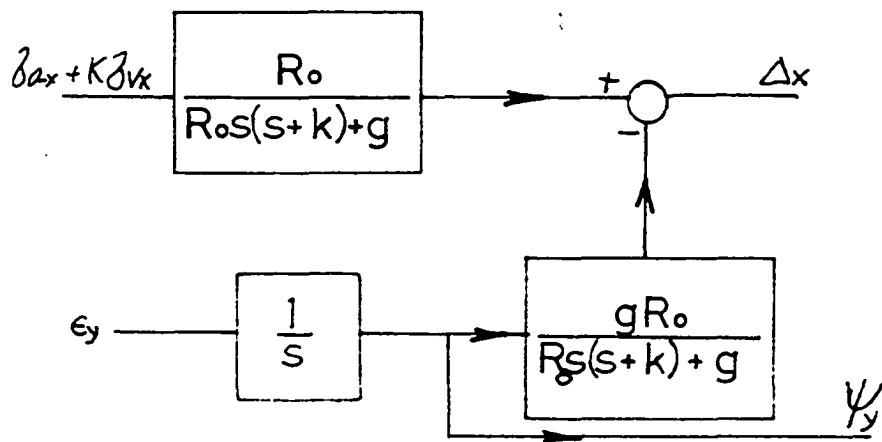

Figure 6. Simplified error block diagram for one channel of a damped inertial system

the sextant, the only useful observation is the altitude of the body in question. This observation establishes a circle of position on the earth's surface. To obtain a position fix, two observations are required. These may be obtained from the same body at two different times, or from two different bodies. This thesis will treat the case of repeated observations on the same body.

If a celestial body tracker is mounted on a stable platform, the observation may be used to sense the component of the difference between platform tilt and position error which is normal to the line of sight. This is shown in Figure 7. Figure 7 shows a cut taken through the center of the earth and including the observer and the line of sight to the celestial body. Providing the platform tilt is small the tracker output is $\psi_y \cos z(t) - \psi_x \sin z(t) + n(t)$, where $n(t)$ is the additive tracker noise and $z(t)$ is the azimuth of the celestial body. Throughout this thesis it has been assumed that only the altitude information is to be used. The reason for doing this is that the azimuth information must be used to correct the platform misalignment about the z axis, which is quite large with respect to the platform tilt about the x and y axes. This information may then be used to correct the position information provided by the inertial system. If the tracker were a perfect instrument there would be fewer problems associated with this correction. However, there are several sources of error in this measurement. Atmospheric refraction is a major problem with either optical or radiometric trackers. If an optical tracker is used weather becomes a factor. If a radiometric tracker is used resolution troubles will be encountered with either the antenna or

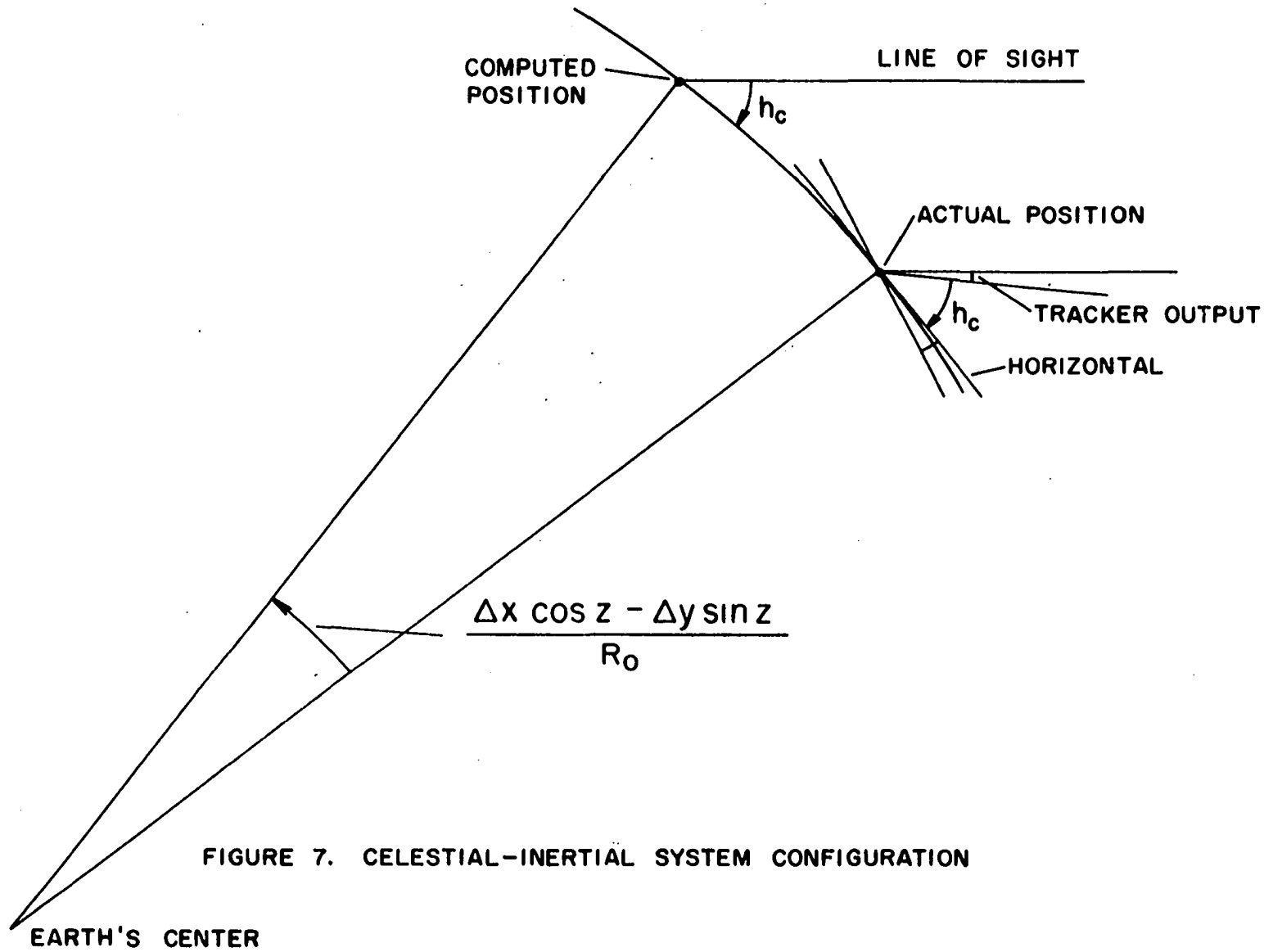

FIGURE 7. CELESTIAL-INERTIAL SYSTEM CONFIGURATION

the random. In any case the problem of optimizing the use of the tracker data is not a trivial one.

Review of the Literature

The topic of this investigation was suggested by work done on a system for the Collins Radio Company by R. G. Brown¹. No optimization of note was done in this work. Optimization of stellar inertial systems has been done in several different cases, and a brief discussion is contained in Pitman (5). The optimization of velocity-inertial systems has been discussed by Porter and Kazda (6). However, their work makes no mention either of celestial systems or of non-time-stationary cases. An earlier paper by Johnson (3) discusses the synthesis of various inertial system configurations. Any search of the literature in this field is complicated by the fact that inertial navigation systems have been used almost exclusively in military applications. For this reason the bulk of the work done in this field is not available to the general public. The most useful work from a general information standpoint has been Pitman (5), which is an excellent source of information on the workings of inertial navigation systems. Most of the material in this chapter on the fundamentals of inertial navigation has been adapted from this source. The works of Laning and Battin (4) and Chang (2) have been very helpful in dealing with non-time stationary filtering and optimization techniques.

¹Brown, R. G., Ames, Iowa. Proposal for an Integrated Radiometric-inertial Autonavigator. Private Communication. 1962.

THE ONE-CHANNEL INERTIAL-CELESTRIAL SYSTEM

Description of the Problem

In this chapter a system consisting of one channel of an inertial system and a tracker with additive noise will be considered. The error block diagram of this system is shown in Figure 8. The tracker output is

$$\int_0^t \epsilon_y(t) dt + n(t) = \psi_y(t) + n(t).$$

It may be noted that the tracker output is independent of both the accelerometer error δa_x and the velocity meter noise δv_x . Consequently, the choice of the optimum feedback function $g(t, t_1)$ depends only on the gyro bias ϵ_y once the velocity meter feedback constant k is chosen. This means that a much simpler system may be considered. This system appears in Figure 9. All further discussion will be based on this configuration. There are several reasons for choosing to operate on ψ_y rather than ϵ_y as an input. It is not necessary to gather data on the autocorrelation function of the derivative of the tracker noise, and the initial condition problem can be handled in a more convenient manner.

Optimization of the One-Channel System

If the statistical properties of the input ψ_y and the noise $n(t)$ are completely known, Δx_d , the component of position error due to gyro bias is

$$\Delta x_d = \int_0^t n(t_1) f(t-t_1) dt_1 - \int_0^t g(t, t_1) [\psi_y(t_1) + n(t_1)] dt_1.$$

This equation is valid for the case where $\psi_y(t)$ has deterministic and

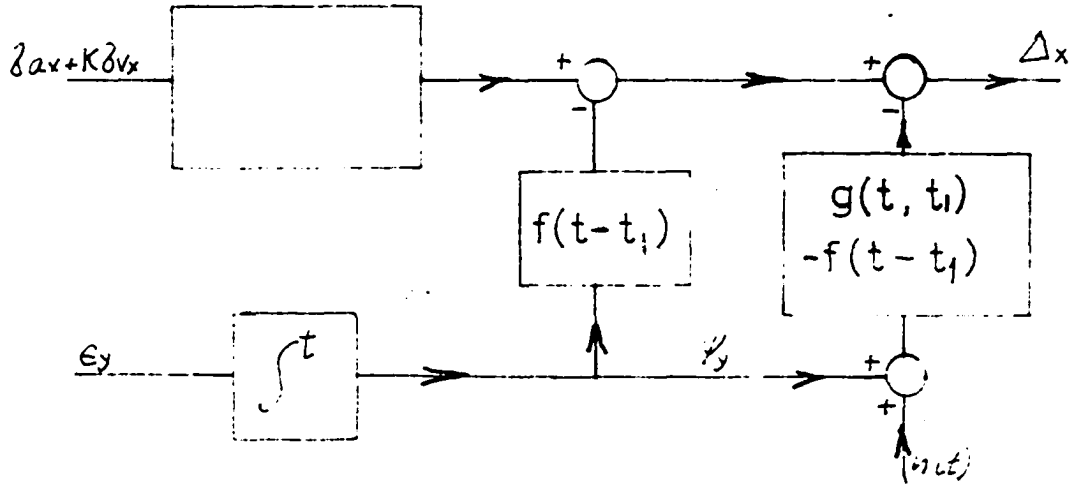

Figure 8. One-channel system with tracker

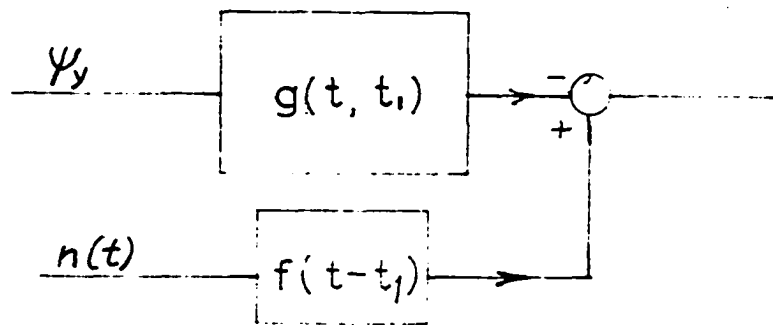

Figure 9. System simplification

random components with completely known statistical properties. The case where the signals consist of random components and deterministic components of unspecified magnitude will be discussed in a subsequent section.

The position error Δx may be minimized by choosing the appropriate weighting function $g(t, t_1)$. The procedure for finding this optimum weighting function is due to Booton (1). It is covered in some detail in the appendix. The integral equation for this optimum weighting function is

$$\int_0^t \gamma_{ii}(t_1, t_2) g(t, t_1) dt_1 = \int_0^t \gamma_{ni}(t_1, t_2) f(t-t_1) dt_1 \quad 0 < t_2 < t$$

where the correlation functions $\gamma_{ii}(t_1, t_2)$ and $\gamma_{ni}(t_1, t_2)$ are defined by

$$\gamma_{ii}(t_1, t_2) = \langle [n(t_1) + \psi_y(t_1)][n(t_2) + \psi_y(t_2)] \rangle$$

$$\gamma_{ni}(t_1, t_2) = \langle n(t_1)[n(t_2) + \psi_y(t_2)] \rangle$$

This integral equation must be solved for each value of time t . No general solution for this type of integral equation is known. Consequently, deriving either a solution or a lower bound for the error is extremely difficult.

By making some assumptions as to the nature of the signal $\psi_y(t)$ the integral equation for the optimum weighting function may be put in a somewhat more intelligible form. These assumptions are: (1) $n(t)$ is time stationary and has the autocorrelation function $Ae^{-b|\tau|}$, (2) ϵ_y is the sum of a constant ϵ_{yk} and a random component ϵ_{yr} with an autocorrelation function $A_y e^{-b_y|\tau|}$, and (3) the noise, the random component of the gyro

bias and the constant portion of the gyro bias are all uncorrelated. The function $\psi_y(t)$ is

$$\psi_y(t) = \int_{t_0}^t \epsilon_{yr}(t) dt + \epsilon_{yk}(t-t_0) + \psi_y(t_0)$$

where t_0 is the time tracking ceased on the previous day and $\psi_y(t_0)$ is thus the value of this error at t_0 .

The autocorrelation function of $\int_{t_0}^t \epsilon_{yr}(t) dt$ is given by the integral

$$\begin{aligned} \gamma_{rr}(t_1, t_2) &= \left\langle \int_{t_0}^{t_1} \epsilon_{yr}(t_3) dt_3 \int_{t_0}^{t_2} \epsilon_{yr}(t_4) dt_4 \right\rangle \\ &= \int_{t_0}^{t_1} \int_{t_0}^{t_2} \langle \epsilon_{yr}(t_3) \epsilon_{yr}(t_4) \rangle dt_3 dt_4 . \end{aligned}$$

This integral has the value

$$\frac{1}{A_y} [b_y(t_1+t_2-2t_0) + b_y|t_1-t_2| - 1 + e^{b_y t_0} [e^{-b_y t_1} + e^{-b_y t_2}] - e^{b_y |t_1-t_2|}] .$$

The autocorrelation function for $\psi_y(t)$ is given below

$$\begin{aligned} \langle \psi_y(t_1) \psi_y(t_2) \rangle &= \langle \psi_y^2(t_0) \rangle + \langle \psi_y(t_0) \epsilon_{yk} \rangle (t_1+t_2-2t_0) + \langle \epsilon_{yk}^2 \rangle \\ &\quad (t_1-t_0)(t_2-t_0) \\ &+ A_y \left[b_y(t_1+t_2-2t_0) + b_y|t_1-t_2| - 1 + e^{b_y t_0} [e^{-b_y t_1} + e^{-b_y t_2}] - e^{b_y |t_1-t_2|} \right] . \end{aligned}$$

The assumption has been made here that some "best value" of position has been set into the system before it reverts to the damped inertial mode

at the end of the previous day's tracking.

The integral equation for the optimum weighting function has the form

$$\int_0^t \langle [\psi_y(t_1) \psi_y(t_2)] + Ae^{-b|t_1-t_2|} \rangle g(t, t_1) dt_1$$

$$= \int_0^t Ae^{-b|t_1-t_2|} g(t-t_1) dt_1, \quad 0 < t_2 < t$$

The "Errorless" Filtering Case

A slightly different approach may be taken to this optimization. This is the so-called "errorless" filtering method. Basically, the optimum filter desired is one which is errorless for the deterministic signals in the absence of noise and which has minimum mean square error when the random signals and noise are present. This method is described by Laning and Battin (4) and is covered in the appendix. If it is desired that this system be errorless in the absence of ϵ_{yr} , $\psi_y(t_0)$, and $n(t)$, i.e., with ϵ_{yk} as the only input, the constraining equation is

$$\int_0^t g(t, t_1) [t_1 - t_0] dt_1 = 0.$$

The position error Δx_q is expressed as before. The optimum weighting function is the one which minimizes the mean square position error subject to the constraining equation. If the terms relating to ϵ_{yk} are removed from ψ_y the integral equation shown below results.

$$\int_0^t [\langle \psi_y^2(t_0) \rangle + \gamma_{rr}(t_1, t_2) + Ae^{-b|t_1-t_2|}] g(t, t_1) dt_1$$

$$= \int_0^t Ae^{-b|t_2-t_1|} f(t-t_1) dt_1 \quad 0 < t_2 < t$$

Because the optimum weighting function gives zero position error for a constant gyro bias it also satisfies this equation. If $g_0(t, t_1)$ is defined as the solution to this equation and $g_1(t, t_1)$ is defined by

$$\int_0^t g_1(t, t_1) [\langle \psi_y^2(t_0) \rangle + \gamma_{rr}(t_1, t_2) + Ae^{-b|t_1-t_2|}] dt_1 = t_2 - t_0$$

then $g(t, t_1)$ is defined as $g_0(t, t_1) + \lambda(t)g_1(t, t_1)$ where $\lambda(t)$ is a Lagrangian multiplier, the optimum weighting function is found by finding g_0 and g_1 and then substituting the resulting $g(t, t_1)$ into the constraining equation to find $\lambda(t)$.

Probably the only analytically solvable case associated with this problem results from a further simplification. If ϵ_{yr} and $\psi_y(t_0)$ are neglected, the integral equations for the errorless problem take the forms

$$\int_0^t g_0(t, t_1) Ae^{-b|t_1-t_2|} dt_1 = \int_0^t Ae^{-b|t_1-t_2|} f(t-t_1) dt_1 \quad 0 < t_2 < t$$

$$\int_0^t g_1(t, t_1) Ae^{-b|t_1-t_2|} dt_1 = t_2 - t_0 \quad 0 < t_2 < t$$

These equations are of the general form

$$\int_a^b U(t_1) \phi(t - t_1) dt_1 = f(t) .$$

This equation is the integral equation for the time independent case with a finite observation time. When $\phi(\tau)$ has a Laplace transform which is a ratio of polynomials in s^2 this equation has an exact solution. This exact solution is described by Laning and Battin (4). The exact solution for these particular equations is relatively simple. The function g_0 is $f(t - t_1)$ by inspection. The function g_1 has an analytical form which is given by Chang (2), for the equation

$$\int_0^t A e^{-b|t_2 - t_1|} g(t + t_1) dt_1 = f(t_2)$$

In the neighborhood of zero it is given by

$$g(t, t_1) = \frac{1}{-2ab} (p + b) [U(t - t_1)(p + b)f(t_1)]$$

These two solutions are equal in the interior of the interval. The complete solution for this case is

$$g_1(t, t_1) = \frac{1}{2ab} [b(t - t_1 - t_0) + (1+b)(t - t_0)\delta(t_1) - (1+bt_0)\delta(t - t_1)]$$

The constraint equation is

$$\int_0^t (t_1 - t_0) f(t - t_1) dt_1 + \lambda(t) \int_0^t (t_1 - t_0) g_1(t, t_1) dt_1 = 0$$

and the Lagrangian multiplier can be determined using this equation by

$$\lambda(t) = \frac{\int_0^t (t_1 - t_0) f(t - t_1) dt_1}{\int_0^t (t_1 - t_0) g_1(t, t_1) dt_1}$$

The optimum weighting function $g(t, t_1)$ is then

$$g(t, t_1) = f(t - t_1) + \lambda(t) g_1(t, t_1)$$

The weighting function $g_1(t, t_1)$ is sketched in Figure 10. The delta functions at the end of the observation interval can be interpreted as discrete observations taken at each end of the observation interval and then added to a weighted average of the remaining data. This is also the sort of weighting function which can be used reasonably easily in a computer mechanization of the system.

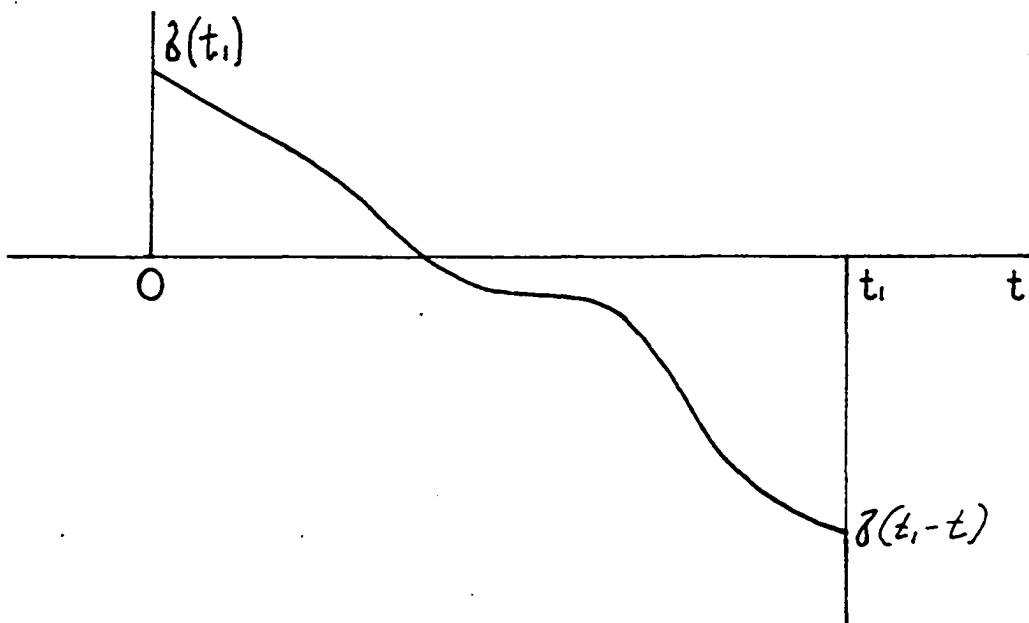

Figure 10. Sample weighting function $g(t, t_i)$

THE OPTIMIZATION OF A TWO-CHANNEL SYSTEM

Description of the Problem

This chapter treats a two-channel inertial navigation system aided by a tracker which tracks one celestial body. The tracker output is thus related to the errors Δx_d and Δy_d . In fact it is the component of ψ normal to the direction of the body being tracked. If the azimuth of the body, $z(t)$, remained constant it would never be possible to determine what portion of the filtered error came from each channel. Fortunately, the azimuth of a celestial body changes as the earth rotates. As a result it is possible to filter the output of the tracker to obtain an approximation to the errors Δx_d and Δy_d . The block diagram of the system to be considered is shown in Figure 11. As in the one-channel system, the only error input which appears in the tracker output is the gyro bias error. Consequently, the simplified block diagram of Figure 12 will be used in the subsequent analysis. A further simplification which can be made in many cases is that the platform tilt is very small, and thus the problem is reduced to minimizing the outputs Δx_d and Δy_d . The simplified block diagram for this case is shown in Figure 13.

Analysis of the System with Negligible Platform Tilt

If the block diagram of Figure 13 is used as a starting point, the output errors Δx_d and Δy_d can be expressed as follows.

$$\begin{aligned} \Delta x_d &= \psi y_1(t) - \int_0^t \psi y_1(t_1) \cos z(t_1) g_1(t, t_1) dt_1 \\ &\quad + \int_0^t \psi x_1(t_1) \sin z(t_1) g_1(t, t_1) dt_1 - \int_0^t n(t_1) g_1(t, t_1) dt_1 \\ \Delta y_d &= x_1(t) - \int_0^t \psi x_1(t_1) \sin z(t_1) g_2(t, t_1) dt_1 \\ &\quad + \int_0^t \psi y_1(t_1) \cos z(t_1) g_2(t, t_1) dt_1 - \int_0^t n(t_1) g_2(t, t_1) dt_1 \end{aligned}$$

From these relationships it is possible to derive the integral equations for the optimum weighting functions. If $s(t)$, the output of the tracker, is defined by

$$s(t) = \psi y_1(t) \cos z(t) - \psi x_1(t) \sin z(t) + n(t)$$

and the correlation functions are defined as

$$\gamma_{ss}(t_1, t_2) = \langle s(t_1) s(t_2) \rangle$$

$$\gamma_{ys}(t, t_2) = \langle \psi y_1(t) s(t_2) \rangle$$

$$\gamma_{xs}(t, t_2) = \langle \psi x_1(t) s(t_2) \rangle$$

then the integral equations for the optimum weighting functions g_1 and g_2 are

$$\gamma_{ys}(t, t_2) = \int_0^t \gamma_{ss}(t_1, t_2) g_1(t, t_1) dt_1 \quad 0 < t_2 < t$$

$$\gamma_{xs}(t, t_2) = \int_0^t \gamma_{ss}(t_1, t_2) g_2(t, t_1) dt_1$$

As in the preceding chapter these equations must be solved for each value of time t . This is true here even for the case of stationary noise.

Probably the most reasonable assumption as to the nature of the gyro bias is that the x and y gyro biases are independent constants. If this assumption is made, then ψ_{y_1} and ψ_{x_1} have the form

$$\psi_{y_1}(t) = \epsilon_y(t-t_0) + \Delta x_d(t_0)$$

$$\psi_{x_1}(t) = \epsilon_x(t-t_0) + \Delta y_d(t_0)$$

where t_0 is the time tracking ceased the previous day. In this case the correlation functions reduce to the forms shown below.

$$\begin{aligned} \gamma_{ss}(t_1, t_2) = & \left\langle \psi_{y_1}(t_1) \psi_{y_1}(t_2) \right\rangle \cos z(t_1) \cos z(t_2) \\ & + \left\langle \psi_{x_1}(t_1) \psi_{x_1}(t_2) \right\rangle \sin z(t_1) \sin z(t_2) \\ \gamma_{ys}(t, t_2) = & \left\langle \psi_{y_1}(t) \psi_{y_1}(t_2) \right\rangle \cos z(t_2) \\ \gamma_{xs}(t, t_2) = & \left\langle \psi_{x_1}(t) \psi_{x_1}(t_2) \right\rangle \sin z(t_2) \end{aligned}$$

Here, the noise and the gyro bias are assumed to be independent.

The integral equations shown above are valid only when the statistical behavior of the noise and the error inputs are completely known. For

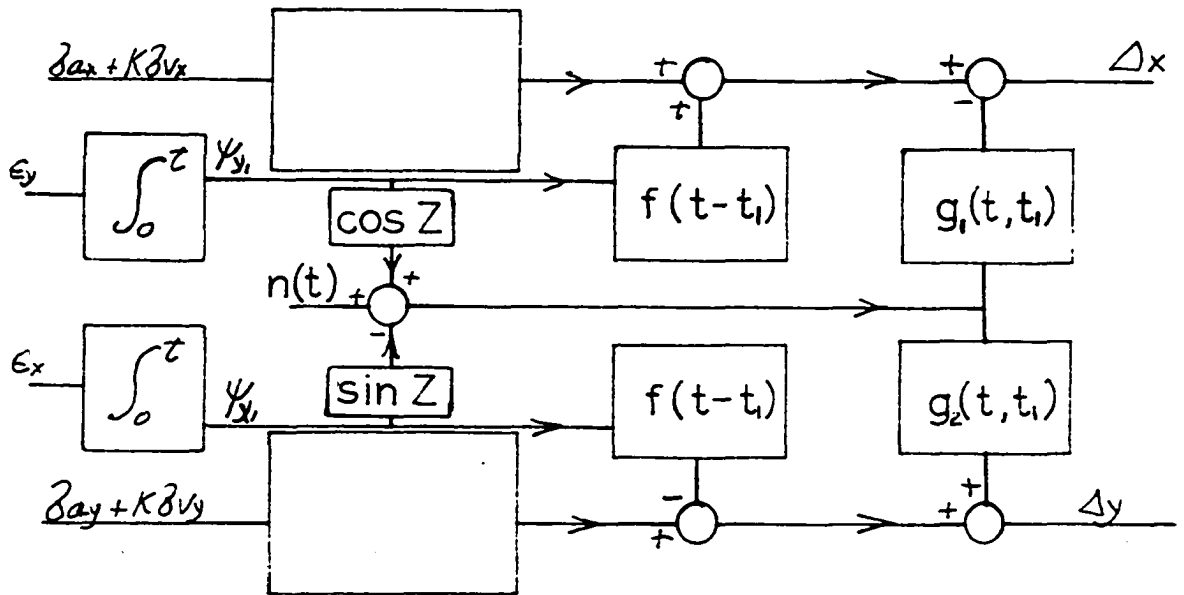

Figure 11. Two-channel inertial system with tracker

some cases this is not a reasonable assumption. In this case the "errorless" filtering technique discussed in the previous chapter may be used. In this case, with the same assumptions as to the nature of the inputs as were made before, the desired weighting functions are the ones which are errorless for constant gyro biases and zero position error at the end of the previous day's tracking. Then the error with noise and error at the end of the previous day is to be made a minimum. This gives two constraining equations on each weighting function. These equations are

$$\int_0^t (t_1 - t_0) \cos z(t_1) g_1(t, t_1) dt_1 = t - t_0$$

$$\int_0^t (t_1 - t_0) \sin z(t_1) g_1(t, t_1) dt_1 = 0$$

$$\int_0^t (t_1 - t_0) \sin z(t_1) g_2(t, t_1) dt_1 = t - t_0$$

$$\int_0^t (t_1 - t_0) \cos z(t_1) g_2(t, t_1) dt_1 = 0$$

The equations for the minimum weighting functions are

$$\gamma_{ys}(t, t_2) = \int_0^t \gamma_{ss}(t_1, t_2) g_1(t, t_1) dt_1 \quad 0 < t_2 < t$$

$$\gamma_{xs}(t, t_2) = \int_0^t \gamma_{ss}(t_1, t_2) g_2(t, t_1) dt_1$$

subject to the equations of constraint above.

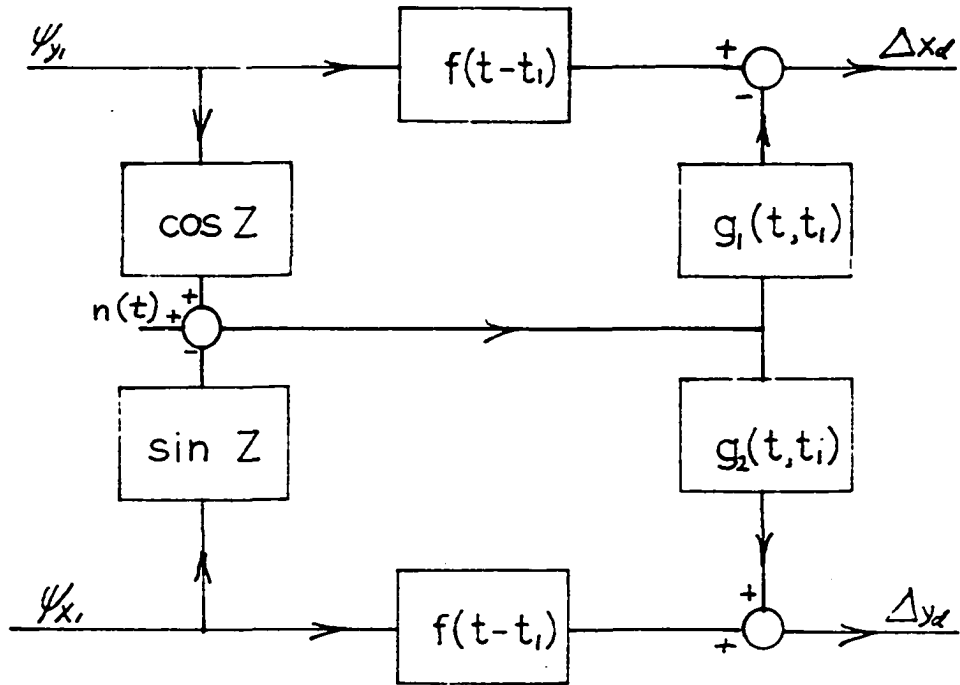

Figure 12. Simplified block diagram

These equations are solved using the method of Lagrangian multipliers.

A discussion of this method may be found in Chang (2). The optimum weighting functions $g_1(t, t_1)$ and g_2 are assumed to be of the form

$$g_1(t, t_1) = g_{10}(t, t_1) + \lambda_{11}(t)g_{11}(t, t_1) + \lambda_{12}(t)g_{12}(t, t_1)$$

$$g_2(t, t_1) = g_{20}(t, t_1) + \lambda_{21}(t)g_{21}(t, t_1) + \lambda_{22}(t)g_{22}(t, t_1)$$

where $g_{10}(t, t_1)$, $g_{11}(t, t_1)$ and $g_{12}(t, t_1)$ are the solutions of the integral equations shown below and λ_{11} and λ_{12} are Lagrangian multipliers.

$$\int_0^t \gamma_{ss}(t_1, t_2) g_{10}(t, t_1) dt_1 = \gamma_{ys}(t, t_2)$$

$$\int_0^t \gamma_{ss}(t_1, t_2) g_{11}(t, t_1) dt_1 = (t_2 - t_0) \cos z(t_2)$$

$$\int_0^t \gamma_{ss}(t_1, t_2) g_{20}(t, t_1) dt_1 = \gamma_{xs}(t, t_2)$$

$$\int_0^t \gamma_{ss}(t_1, t_2) g_{12}(t, t_1) dt_1 = (t_2 - t_0) \sin z(t_2)$$

Once the solutions for these integral equations are found, the weighting function formed from them can be substituted back into the constraining equations to find the Lagrangian multipliers and thus the desired weighting function. If, as in the preceding chapter, it is assumed that the random component of the gyro bias is zero, the error $\psi(t_0)$ is negligible, and the noise has the autocorrelation function $Ae^{-b|\tau|}$, then the

integral equations for the partial weighting functions are as shown below.

$$0 = \int_0^t g_{10}(t, t_1) A e^{-b|t_2 - t_1|} dt_1 = \int_0^t g_{20}(t, t_1) A e^{-b|t_2 - t_1|} dt_1$$

$$(t_2 - t_0) \cos z(t_2) = \int_0^t A e^{-b|t_2 - t_1|} g_{11}(t, t_1) dt_1$$

$$(t_2 - t_0) \sin z(t_2) = \int_0^t A e^{-b|t_2 - t_1|} g_{21}(t, t_1) dt_1$$

$$g_{11} = g_{22} \quad g_{21} = g_{12}$$

g_{10} and g_{20} are zero by inspection. g_{11} , g_{12} , g_{21} , and g_{22} may be obtained by the same methods used previously. These functions do not need to be calculated for each value of time. However, they are different for each function $z(t)$. Once these functions are found, they must be substituted back into the constraining equations to find the Lagrangian multipliers. This substitution will give two sets of equations in the multipliers. These are shown below.

$$I_{11} = \int_0^t (t_1 - t_0) g_{11}(t, t_1) \cos z(t_1) dt_1$$

$$I_{22} = \int_0^t (t_1 - t_0) g_{12}(t, t_1) \sin z(t_1) dt_1$$

$$I_{12} = \int_0^t (t_1 - t_0) g_{12}(t, t_1) \cos z(t_1) dt_1$$

$$I_{21} = \int_0^t (t_1 - t_0) g_{11}(t, t_1) \sin z(t_1) dt_1$$

$$t - t_0 = \lambda_{11}(t) I_{11} + \lambda_{12} I_{12}$$

$$0 = \lambda_{11} I_{21} + \lambda_{12} I_{22}$$

$$t - t_0 = \lambda_{21} I_{22} + \lambda_{22} I_{21}$$

$$0 = \lambda_{21} I_{11} + \lambda_{22} I_{12}$$

It may be seen that even for this simplified case the solution of the optimization equations is very difficult.

The System with Appreciable Platform Tilt

The block diagram for the system with non-negligible platform tilt appears in Figure 12. The position errors Δx_d and Δy_d for this system are

$$\begin{aligned} \Delta x_d = & \int_0^t \psi y_1(t_1) f(t-t_1) dt_1 - \int_0^t \psi y_1(t) \cos z(t_1) g_1(t, t_1) dt_1 \\ & + \int_0^t \psi x_1(t_1) \sin z(t_1) g_1(t, t_1) dt_1 - \int_0^t n(t_1) g_1(t, t_1) dt_1 \end{aligned}$$

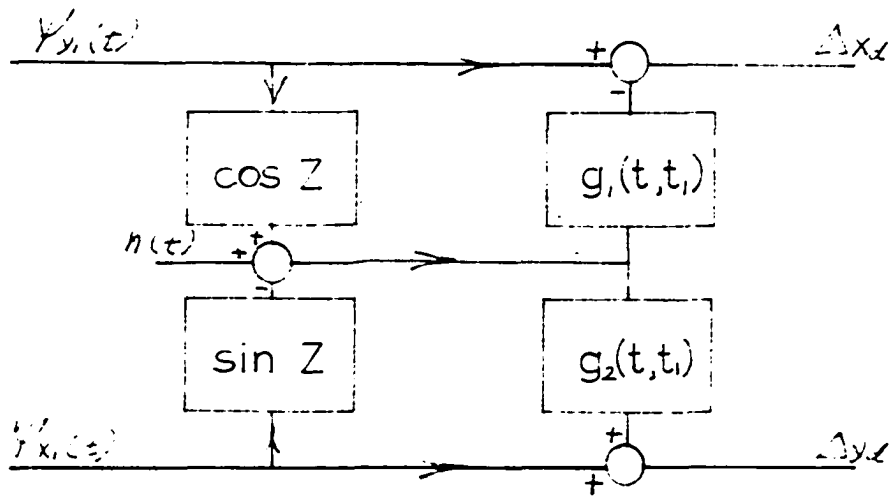

Figure 13. System with negligible platform tilt

$$\Delta y_d = - \int_0^t \psi_{x_1}(t_1) f(t-t_1) dt_1 + \int_0^t \psi_{x_1}(t_1) \sin z(t_1) g_1(t, t_1) dt_1 \\ + \int_0^t \psi_{y_1}(t) \cos z(t_1) g_1(t, t_1) dt_1 - \int_0^t n(t_1) g_1(t, t_1) dt_1$$

In a manner analogous to that used in the preceding section, the integral equations for the optimum weighting function are

$$\int_0^t \gamma_{ss}(t_1, t_2) g_1(t, t_1) dt_1 = \int_0^t f(t-t_1) \gamma_{ys}(t_1, t_2) dt_1 \\ \int_0^t \gamma_{ss}(t_1, t_2) g_2(t, t_1) dt_1 = \int_0^t f(t-t_1) \gamma_{xs}(t_1, t_2) dt_1$$

These equations are valid when the statistical behavior of the inputs and noise are completely known. The technique for their solution is very similar to that which must be used for the equations of the previous section. As was true with the case of negligible platform tilt, these equations must be solved for each value of time t . If the "errorless" filtering method is used, the equations of constraint become

$$\int_0^t (t_1 - t_0) \cos z(t_1) g_1(t, t_1) dt_1 = \int_0^t f(t-t_1) (t_1 - t_0) dt_1 \\ \int_0^t (t_1 - t_0) \sin z(t_1) g_1(t, t_1) dt_1 = 0 \\ \int_0^t (t_1 - t_0) \cos z(t_1) g_2(t, t_1) dt_1 = 0$$

$$\int_0^t (t_1 - t_0) \sin z(t_1) g_2(t, t_1) dt_1 = \int_0^t f(t - t_1) (t_1 - t_0) dt_1$$

The integral equations for the optimum filters which must be solved subject to these constraints are the same as those above, with the exception that the terms relating to ϵ_{yk} are removed from the correlation functions. If the partial weighting functions are now defined by the integral equations

$$\int_0^t \gamma_{ss}(t_1, t_2) g_{11}(t, t_1) dt_1 = (t_2 - t_0) \cos z(t_2)$$

$$\int_0^t \gamma_{ss}(t_1, t_2) g_{12}(t, t_1) dt_1 = (t_2 - t_0) \sin z(t_2)$$

$$g_{11} = g_{22} \quad g_{21} = g_{12}$$

the optimum weighting functions may again be expressed as

$$g_1(t, t_1) = \lambda_{10} g_{10}(t, t_1) + \lambda_{11} g_{11}(t, t_1) + \lambda_{12} g_{12}(t, t_1)$$

$$g_2(t, t_1) = \lambda_{20} g_{20}(t, t_1) + \lambda_{21} g_{21}(t, t_1) + \lambda_{22} g_{22}(t, t_1)$$

The right sides of the integral equations for the partial weighting functions are known functions of t . Except for the equations for the partial weighting functions g_{10} and g_{20} , there is no difference between the integral equations for this case and the case with negligible platform error. The constraining equations are different, however, and thus the weighting functions will also be different. If the same assumptions are

made about the noise and the gyro bias as were made in the preceding section, the weighting functions g_{10} and g_{20} are zero and thus the only change to be made in considering the effects of platform tilt is to change the constraining equations used when determining the Lagrangian multipliers. This means that the effects of varying the velocity meter constant k are much easier to assess, since they appear only in the Lagrangian multipliers.

Closed-Loop System Configurations

It may not seem at all obvious that the system configuration shown in Figure 14 can ever be reduced to the form used as a general form for the optimization. The form shown in Figure 14 uses direct feedback to the gyro bias input; and it has four weighting functions involved instead of the two of the system of Figure 13. However, it can be done, and the fact that it can be done validates a considerable portion of this analysis. Consider the configurations shown in Figure 15. If the closed-loop response to a unit impulse $u_0(t-t_1)$ is known to be $g(t,t_1)$ then the integral equation

$$\delta(t-t_1) = g(t,t_1) + \int_{t_1}^t g(t,t_2)q(t_2,t_1)dt_2$$

can be used to find the feedback weighting function $q(t,t_1)$. Conversely, if q is known, the same integral equation can be used to find the closed-loop response $g(t,t_1)$. The significance of this integral equation is that if $q(t,t_1)$ represents a physically realizable weighting function then $g(t,t_1)$ does also and vice-versa. Thus it is possible to solve for the

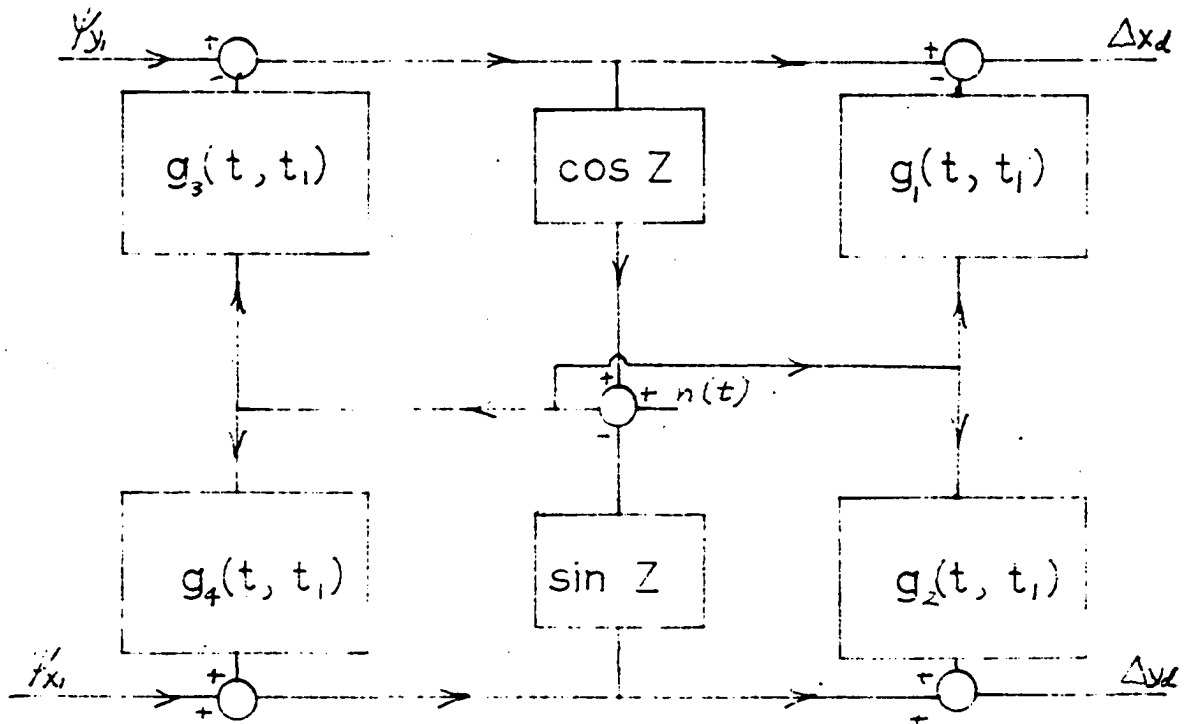

Figure 14. Possible closed-loop system

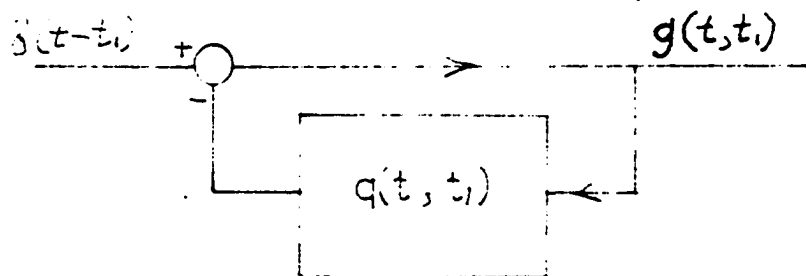

Figure 15. Simple closed-loop configuration

closed-loop optimization function and know that this represents the true optimization function and that it is not possible to improve matters by using a more complicated system configuration. Now consider the configuration of Figure 16. This is merely a revision of Figure 14. However, it is now much more apparent that this configuration will not accomplish any more than the configurations previously studied. The integral equations necessary to describe the feedback transfer functions may be difficult to solve, but particularly with digital techniques, the mechanization using the closed loop weighting functions may be entirely satisfactory. Further, it provides a direct method for computing the mean square value of the position error and so may be used as a standard of comparison for existing or proposed practical systems. The weighting function $U(t, t_1)$ of Figure 16(c) is defined by the integral equation

$$U_0(t, t_1) = m(t, t_1) + \int_0^t m(t, t_1) [g_3(t, t_2) \cos z(t_2) - g_4(t, t_2) \sin z(t_2)] dt_2$$

and the total weighting functions composed of m , g_3 , and g_1 , and their counterparts m , g_2 and g_4 are

$$g_y(t, t_1) = \int_0^t m(t_2, t_1) [g_3(t_2, t_2) + g_1(t_2, t_2)] dt_2$$

$$g_x(t, t_1) = \int_0^t m(t_2, t_1) [g_2(t_2, t_2) + g_4(t_2, t_2)] dt_2$$

for the Δx_d side and the Δy_d side respectively.

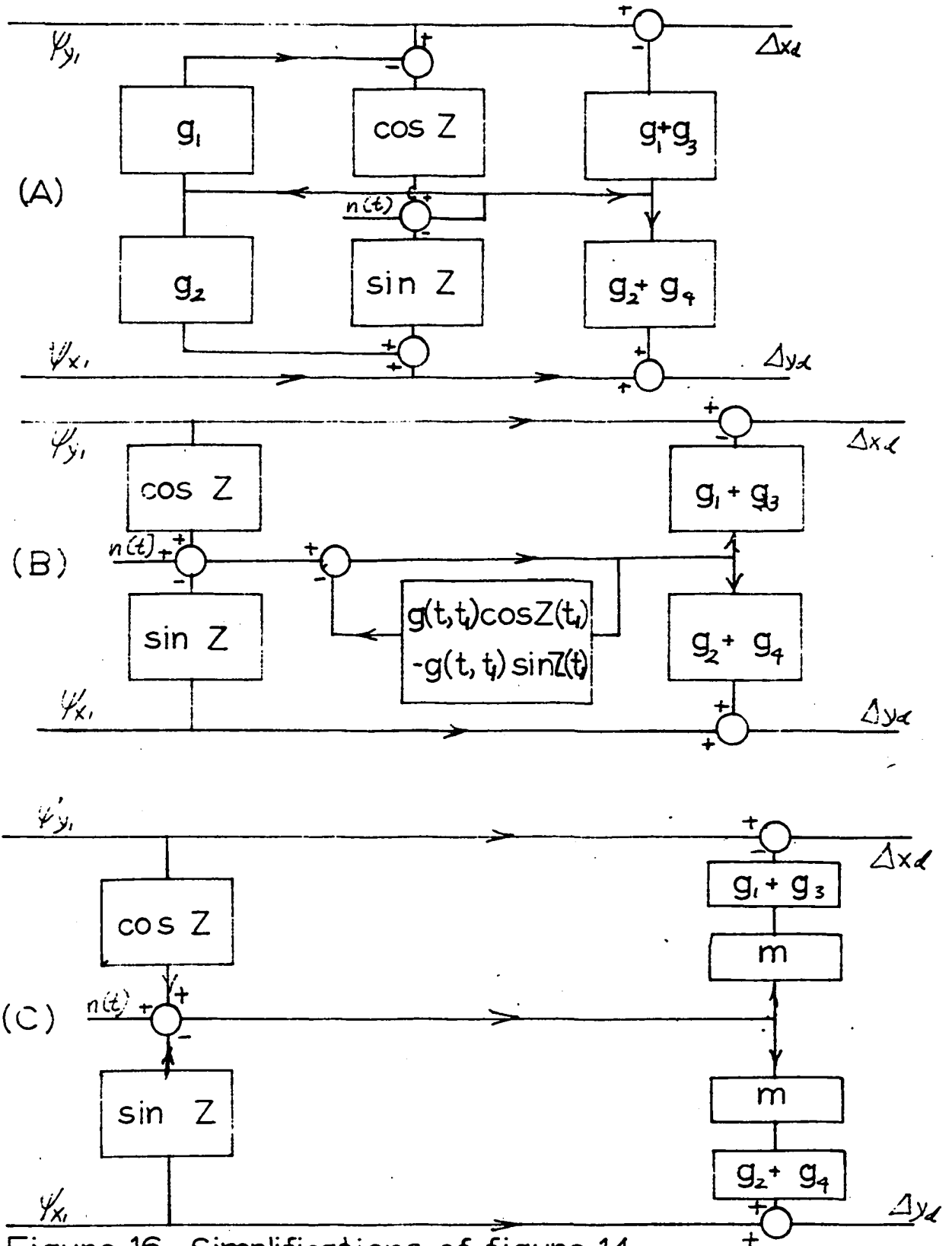

Figure 16. Simplifications of figure 14

CONCLUSIONS

This thesis describes methods of optimizing a combined celestial-inertial navigation system using the altitude information from a celestial body tracker. The integral equations for the optimum weighting functions are derived for several cases. In any case where the noise or the random component of the gyro bias is unknown, no closed form solution is known for the weighting functions, and in addition the integral equations for the weighting functions must be solved for each value of time. This means that any solution for these cases must be extremely difficult. It has not been possible to establish even a tentative error bound for any of these cases. When the gyro bias is assumed to be constant, and the noise is assumed to have a simple autocorrelation function, then the problem has a somewhat simpler solution. In this case, the integral equations for the partial weighting functions have an analytical solution in which the time appears. These partial weighting functions can then be substituted back into the original equations of constraint in order to determine the complete weighting function. The resulting weighting functions can then be used to determine the mean square value of the position error. However, for the two-channel system such a calculation would be extremely difficult.

Two different optimization criteria have been used in deriving the optimum weighting functions. Basically, these both result in minimum mean square error, but under different assumptions with regard to the nature of the inputs. In the first, the statistical behavior of the signal and noise are assumed to be completely known. Then the appropriate ensemble averages of all the necessary functions can be determined and the equations

for the minimization set up. In the second, the system is forced to be errorless when the noise and random components are not present. The error in the presence of the random components and noise is minimized in the mean square sense by the choice of the optimum weighting function from among those satisfying the constraining equations which specify that the system is errorless for the deterministic inputs.

In the practical design of a system, the choice between these methods of filtering appears to depend on a rather intimate knowledge of the properties of the gyros. In general, the most devastating form of gyro error would be random components of ϵ_y and ϵ_x . Constant drifts would be relatively easily compensated for, provided the tracker noise is not extremely high. The worst situation appears to be the combination of large amounts of tracker noise and large amounts of random gyro bias.

Several simplified approaches appear to be useful for this system. One appears to be to assume a simplified form for $\sin z$ and $\cos z$ and solve for these weighting functions. The result would probably be useful in the design of a practical system. Another approach, and probably the only one which would be of much help if the case of non-stationary noise is to be considered is to reduce the integral equations to sets of linear equations by assuming a weighting matrix rather than a weighting function of two variables.

In short, this thesis sets up the equations for the optimum weighting functions. It does not attempt to solve them for cases complex enough to be of practical interest.

LITERATURE CITED

1. Booton, R. C., Jr. An optimization theory for time-varying linear systems with non-stationary statistical inputs. Proceedings Institute of Radio Engineers. 40: 977-981. 1952.
2. Chang, S. S. L. Synthesis of optimum control systems. New York, N. Y., McGraw-Hill Book Co., Inc. 1961.
3. Johnson, F. The synthesis of velocity-inertial navigation systems. National Electronics Conf. Proc. 15: 784-793. 1959.
4. Laning, J. H., Jr. and R. H. Battin. Random processes in automatic control. New York, N. Y., McGraw-Hill Book Co., Inc. 1956.
5. Pitman, G. R., ed. Inertial guidance. New York, N. Y., John Wiley and Sons, Inc. 1962.
6. Porter, W. A. and L. F. Kazda. Optimization of a velocity-inertial navigation system. Institute of Radio Engineers Trans. on Aerospace and Navigational Electronics 8: 72-77. 1961.
7. Zadeh, L. A. and J. R. Ragazzini. An extension of Wiener's theory of prediction. Journal of Applied Physics 21: 645-655. 1950.

ACKNOWLEDGEMENTS

The author wishes to express his thanks to his major professor, Dr. R. G. Brown, for his suggestion of the topic of this investigation and also for his assistance during the preparation of the manuscript.

APPENDIX A

The Non-Time-Stationary Optimum Filtering Problem

The non-time-stationary filtering problem was first solved by Booton (1). The modification of this problem which takes into account the problem of optimum filtering with constraints is discussed by Laning and Battin (4). Basically the problem is the optimum filtering of a signal and noise in additive combination so that the error, or difference between the output of an optimum filter and the desired signal, is to be made a minimum in the mean-square sense. The noise and signal are assumed to be random, and the necessary data regarding their statistical behavior is assumed to be known. The case considered here is slightly different in superficial appearance from the more usual configuration, however it is more convenient for the purposes of this thesis.

Consider the system shown in the block diagram of Figure 17. It is desired to find the optimum physically realizable weighting function $g_0(t, t_1)$ such that the ensemble average of the square of $e(t)$ is to be made a minimum. The error can be written

$$e(t) = \int_0^t h(t, t_1)n(t_1)dt_1 - \int_0^t g(t, t_1)s(t, t_1)dt_1$$

and its mean square value can be written

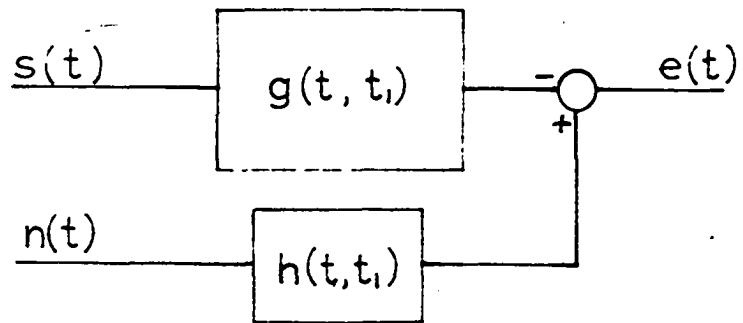

Figure 17. System configuration

$$\begin{aligned}
\langle e^2(t) \rangle &= \int_0^t \int_0^t h(t, t_1) h(t, t_2) \gamma_{nn}(t_1, t_2) dt_1 dt_2 \\
&\quad - 2 \int_0^t \int_0^t h(t, t_1) g(t, t_2) \gamma_{ns}(t_1, t_2) dt_1 dt_2 \\
&\quad + \int_0^t \int_0^t g(t, t_1) g(t, t_2) \gamma_{ss}(t_1, t_2) dt_1 dt_2
\end{aligned}$$

where the correlation functions γ_{nn} , γ_{ns} , and γ_{ss} are given by

$$\begin{aligned}
\gamma_{nn}(t_1, t_2) &= \langle n(t_1) n(t_2) \rangle \\
\gamma_{ns}(t_1, t_2) &= \langle n(t_1) s(t_2) \rangle \\
\gamma_{ss}(t_1, t_2) &= \langle s(t_1) s(t_2) \rangle
\end{aligned}$$

Any physically realizable weighting function can be written in the form $g(t, t_1) = g_0(t, t_1) + a g_1(t, t_1)$ where $g_1(t, t_1)$ is a physically realizable weighting function whose form depends on g_0 , a , and the specified $g(t, t_1)$. When this substitution is made $\langle e^2(t) \rangle$ can be expressed in the quadratic form $F_0 + a F_1 + a^2 F_2$ where F_0 , F_1 , and F_2 are as shown below.

$$\begin{aligned}
F_0 &= \int_0^t \int_0^t h(t, t_1) h(t, t_2) \gamma_{nn}(t_1, t_2) dt_1 dt_2 \\
&\quad - 2 \int_0^t \int_0^t h(t, t_1) g_0(t, t_2) \gamma_{ns}(t_1, t_2) dt_1 dt_2 \\
&\quad + \int_0^t \int_0^t g_0(t, t_1) g_0(t, t_2) \gamma_{ss}(t_1, t_2) dt_1 dt_2
\end{aligned}$$

$$\begin{aligned}
F_1 &= 2 \int_0^t \int_0^t h(t, t_1) g_1(t, t_2) \gamma_{ns}(t_1, t_2) dt_1 dt_2 \\
&\quad - 2 \int_0^t \int_0^t g_0(t, t_1) g_1(t, t_2) \gamma_{ss}(t_1, t_2) dt_1 dt_2 \\
F_2 &= \int_0^t \int_0^t g_1(t, t_1) g_1(t, t_2) \gamma_{ss}(t_1, t_2) dt_1 dt_2
\end{aligned}$$

Regardless of the functions g_0 and g_1 , F_0 and F_2 will both be positive. This is the case since they are the ensemble averages of the square of a real quantity. For example, F_2 is the ensemble average

$$\left\langle \left[\int_0^t g_1(t, t_1) s(t_1) dt_1 \right]^2 \right\rangle$$

The desired condition for minimum error is that $F_0 + aF_1 + a^2F_2$ be a minimum when a is zero. This means that it is a minimum when the weighting function is g_0 . The error is a minimum if $\frac{d}{da} \langle e^2(t) \rangle = 0$ and

$$\frac{d^2}{da^2} \langle e^2(t) \rangle > 0, \text{ for any arbitrary } g_1(t, t_1). \text{ The derivative } \frac{d}{da} \langle e^2(t) \rangle$$

is zero if F_1 is zero for any physically realizable g_1 . F_2 is positive for the reasons discussed above. Consider the form of F_1

$$2 \int_0^t g_1(t, t_2) \left[\int_0^t h(t, t_1) \gamma_{ns}(t_1, t_2) dt_1 - \int_0^t g_0(t, t_1) \gamma_{ss}(t_1, t_2) dt_1 \right] dt_2.$$

In order for this integral to be zero for any arbitrary $g_1(t, t_2)$, the expression inside the brackets must be zero for any t_2 between the limits of integration. This yields the integral equation

$$\int_0^t h(t, t_1) \gamma_{ns}(t_1, t_2) dt_1 = \int_0^t g_0(t, t_1) \gamma_{ss}(t_1, t_2) dt_1$$

which must be satisfied for $0 < t_2 < t$. This completes the solution of the problem for the case where the statistical data concerning the relative magnitudes of the noise and the signal are all known.

In some cases a different version of this problem is encountered. This is the case where the signal $s(t)$ may contain some components of known form and unknown magnitude. It is desired to have the output be a desired linear functional on the input for the case where the random components of signal and noise are zero, and to have the mean square error be a minimum in the presence of signal and noise. The errorless behavior in the absence of the random components can be expressed by the constraining equation

$$\int_0^t f(t_1) g(t, t_1) dt_1 = f_0(t)$$

where $f(t)$ is the known input signal, and $f_0(t)$ is the desired output in the absence of noise. The condition for minimum error in the presence of the random components remains the same as before. This problem may be solved using the method of Lagrangian multipliers. The Lagrangian may be written

$$F_0 + a[F_1 - \lambda(t) \int_0^t f(t_2) g_1(t, t_2) dt_2] + a^2 F_2 - \lambda(t) \left[\int_0^t f(t_2) g_0(t, t_2) dt_2 - f_0(t) \right]$$

where $\lambda(t)$ is the Lagrangian multiplier. The condition that $\frac{d}{da} \langle e^2(t) \rangle$ be zero is represented by the equation

$$\int_0^t g_1(t, t_2) \left[\int_0^t h(t, t_1) \gamma_{ns}(t_1, t_2) dt_1 \int_0^t g_0(t, t_1) \gamma_{ss}(t, t_2) dt_1 - \lambda(t) f(t_2) \right] dt_2$$

Since this must be zero for any arbitrary g_1 , it means that the integral equation

$$\int_0^t h(t, t_1) \gamma_{ns}(t_1, t_2) dt_1 - \int_0^t g_0(t, t_1) \gamma_{ss}(t_1, t_2) dt_1 - \lambda(t) f(t_2) dt_2 = 0$$

must be satisfied. Once the solution to this equation is determined it must be substituted back into the constraining equation to determine $\lambda(t)$.

The functions g_{00} and g_{01} are defined by the integral equations

$$\int_0^t g_{00}(t, t_1) \gamma_{ss}(t_1, t_2) dt_1 = \int_0^t h(t, t_1) \gamma_{ns}(t_1, t_2) dt_1$$

$$\int_0^t g_{01}(t, t_1) \gamma_{ss}(t_1, t_2) dt_1 = f(t_2)$$

If the value $g_0 = g_{00} + \lambda(t)g_{01}$ is substituted into the integral equation for g_0 it may be seen that this value is a solution for any $\lambda(t)$. The optimum $g_0(t, t_1)$ is then determined by finding the necessary value of $\lambda(t)$ by substituting back into the constraining equation.

If all the statistical data concerning the inputs is known, then the

first method will give least error. However, if the relative magnitudes of signal and noise are not known, then the second method must be used. In some cases, the second method yields somewhat easier analytical solutions.